

STANNAH LIFTS LTD

**TECHNICAL BULLETIN****INFORMATION ONLY**

---

**For the Attention of :** Installers, Testers, Trade Customers, Training Dept,**Date :** 21/12/09**Product :** Traction Passenger Lifts - Maxilift**Subject :** Changes to Uninterruptable Power Supply (UPS)**Status :** Product Update - Information only**Pages :** 2

---

**Originator :** Stannah Lifts Ltd, Anton Mill, Andover, Hants SP10 2NX 01264 339090

---

**Detail**

The model of UPS used on traction lifts has changed from ref. ERA 1.0 to ref. ERA LCD 1.1 due to the previous unit being discontinued by the manufacturer. The new model is identifiable by an LCD screen located on the front of the unit.

The new unit, due to its revised overall dimensions should now be mounted on its side with the base towards the control panel backplate as shown. Secure the unit to the backplate with cable ties ensuring the eye of the cable tie is clear of the cabinet door stiffener. A cut-out has been added to the door stiffener to prevent any interference as this may result in difficulty in closing the door.

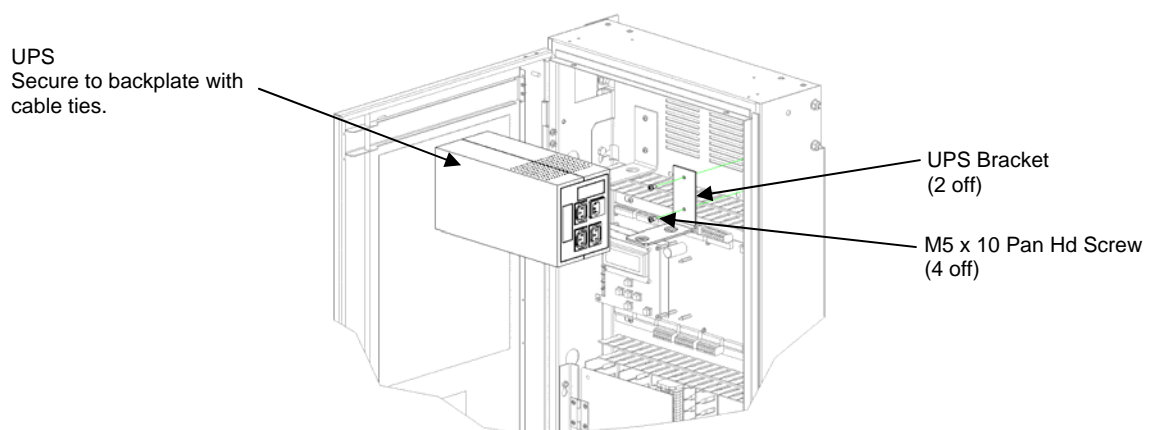

Connections to UPS are unchanged and are labelled on the unit.

Note: The red "Filtered Outlet" is **not** used.

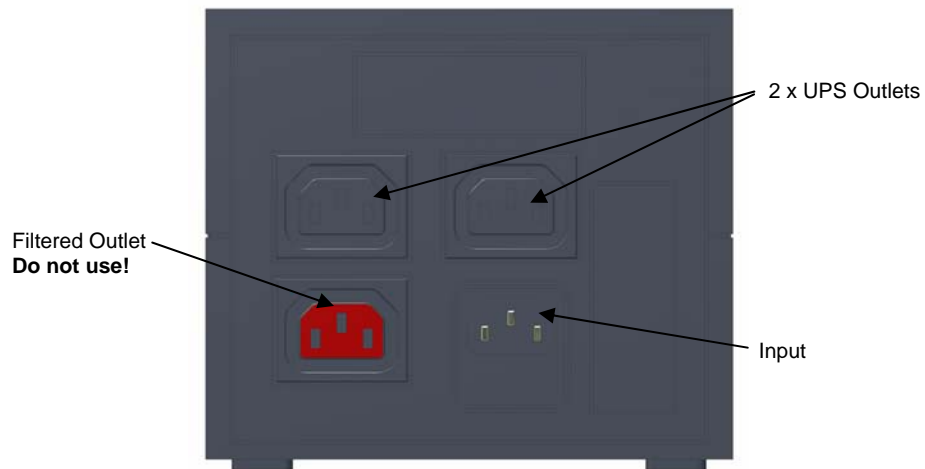

This change applies to all traction lifts manufactured from 07/12/09.